



**Elektrosvit**

Svatobořice, a. s.

INSTALLATION AND MAINTENANCE  
INSTRUCTIONS  
EXPLOSION-PROOF LUMINAIRE



# ORION LED





**Elektrosvit**

Svatobořice, a. s.

## Contents

1.	Basic information .....	3
2.	Description of the luminaire .....	4
3.	Description of the luminaire .....	5
4.	Assembly and installation .....	6
5.	Safety precautions .....	6
6.	Lamp maintenance .....	7
7.	Spare parts .....	8
8.	Packaging, delivery, storage and accompanying documentation .....	9
9.	Special conditions of use .....	9
10.	Dimensional drawing .....	10
11.	Configurator .....	11



## 1. Basic information

Name: ORION LED

Type: 591 39 04, 591 39 05



II 2G Ex db eb description IIC T6...T5 Gc

II 2D Ex tb op is IIIC T80°C... 90°C Dc

IP66

### II 2G Ex db eb description IIC T6...T5 Gc

- **II:** Equipment group II (intended for explosive atmospheres in non-mining areas).
- **2G:** Equipment intended for use in Zone 1 (area where explosive atmospheres may be present under normal conditions).
- **Ex:** Marking for equipment intended for explosive atmospheres.
- **db :** Explosion protection, where the device prevents the spread of flames.
- **eb :** Increased safety, the device is designed to be safe when operating with this protection.
- **description :** Operating temperature range (this term is usually related to the surface temperature of the device) .
- **IIC:** Equipment suitable for use in explosive gas atmospheres containing hydrogen, acetylene or other highly explosive gases.
- **T6...T5:** Temperature classes. T6 means a maximum surface temperature of 85°C , T5 means 100°C. This indicates the temperature range in which the device can operate without the risk of ignition of the surrounding gases.
- **Gc :** Level of protection of the device against gases (category 2, for protection against ignition).

### II 2D Ex tb op is IIIC T80°C... 90°C Dc

- **II:** Equipment group II (intended for explosive atmospheres in non-mining areas).
- **2D :** Equipment intended for use in Zone 21 (area where explosive dust atmospheres may be present under normal conditions).
- **Ex:** Marking for equipment intended for explosive atmospheres.
- **tb :** Explosion protection, where the device is protected against dust, it is dust-tight.
- **description :** Operating temperature range (again related to the surface temperature of the device) .
- **IIIC:** Equipment suitable for use in explosive dust atmospheres (e.g. flour dust, coal dust or metal dust).
- **T80°C... 90°C :** Temperature range of the class, meaning that the maximum surface temperature of the device can be between 80°C and 90°C.
- **Dc :** Level of protection of the device against dust (category 2, for protection against ignition).

### IP66 :

- **IP :** Degree of protection of the device against solid objects (e.g. dust) and water.
- **66 :**
  - **6** means complete protection against dust, the device is dustproof.



# Elektrosvit

Svatobořice, a. s.

- **6** means protection against strong jets of water (including heavy rain or water jets), and the device is water resistant even in very harsh conditions.

The luminaire is certified for use in environments according to **ATEX** specifications for **zone 1** and **zone 2 1** , which indicates the presence of explosive gases, vapors or dust mixtures, in accordance with **ATEX standards** . The luminaire's design meets the requirements of directives and harmonized standards according to EU requirements , which is confirmed by the declaration of conformity.

The luminaire is ideal for installations in hazardous areas where a high level of safety and reliability is required. Typical applications include:

- **Industrial areas** : production and storage areas where flammable substances are handled (e.g. chemical, petrochemical or pharmaceutical plants).
- **Oil and gas facilities** : environments with the presence of flammable gases and vapors.
- **Mining industry** : areas where dust may occur (e.g. in cement plants or other industrial facilities other than mines ).
- **Agricultural operations** : storage and handling of flammable dusty materials (e.g. grain, flour).

#### Usage restrictions:

- The luminaire must not be used outside the specified zones 1/2 1 and 2/22 .
- Installation and maintenance must be carried out by qualified personnel who are familiar with ATEX requirements.
- Before using in new applications, it is necessary to check whether the luminaire is compatible with the specific environment.

## 2. Luminaire description

The body of the luminaire is made of aluminum alloy with low content of Mg, Ti and Zr. The light-transmitting part is made of durable tempered glass . The entire luminaire is sealed with a rubber seal, which is designed for very high temperatures. The luminaire uses terminals that ensure safe and spark-free connection of internal conductors and supply cables. The cable gland has a protection degree of IP68 at 10 bar and IP69K. It has an ATEX certificate and is made of high-quality stainless steel.

Compliance with the essential health and safety requirements is ensured by verifying compliance with:

**ČSN EN IEC 60079-0:2018; ČSN EN 60079-1:2015; ČSN EN 60079-31:2014;  
ČSN EN 60079-7:2017+A1:2018; ČSN EN 60079-28:2016**

**The product complies with the standards ČSN EN IEC 60079-0:2018, ČSN EN IEC 60079-15:2019, ČSN EN 60079-31:2014 and the ATƏX directive 2014/34/EU.**



## 3. Luminaire description

TYPE	Power consumption	Voltage	Protection class	Current	Efficiency	Explosion-proof marking
591 39 04	50W	198-264 V AC / 176-280 V DC / 50-60 Hz	AND	0.22A	0.97 cosφ	II 2G Ex db eb description IIC T5 Gc II 2D Ex tb op is IIIC T90°C Dc
591 39 05	30W			0.13A		II 2G Ex db eb description IIC T6 Gc II 2D Ex tb op is IIIC T80°C Dc

Type	Luminous flux	Efficiency	Beam angle	Color temperature	Color rendering index
591 39 04	7,100 lumens	142 lm /W	120°	3000K , 4000K 5000K , 5700K 6000K , 6500K	>80
591 39 05	4,365 lumens	146 lm /W			

Type	Ta - 40°C <> + 50°C
591 39 04	100,000 hours / L90B10
591 39 05	100,000 hours / L90B10

### Maximum circuit breaker load and number of lights connected in series

Circuit breaker :	C10	C13	C16	C20	B10	B13	B16	B20	Inrush current	
Cross section conductors :	1.5 mm <sup>2</sup>	1.5 mm <sup>2</sup>	2.5 mm <sup>2</sup>	4mm <sup>2</sup>	1.5 mm <sup>2</sup>	1.5 mm <sup>2</sup>	2.5 mm <sup>2</sup>	4mm <sup>2</sup>	I <sub>max</sub>	Time
Number of lights :	5	7	8	10	3	4	5	6	65 A	268 μs



## 4. Assembly and installation

The installation and electrical connection of the luminaire must be in accordance with the requirements of the **ČSN EN IEC 60079-14 standard**, which regulates the safety requirements for equipment used in areas with a risk of explosion.

### 1. Fastening luminaires:

The luminaire can be fixed firmly to the ceiling, wall or structure. The luminaire can be mounted both with and without a bracket, as a pendant. It is necessary to make sure that the luminaire is correctly fixed and the luminaire is stable.

### 2. Electric Connection:

Insert the power cable into the luminaire through the cable gland. Carefully strip the wires and insert them into the terminal block according to the markings on the terminal block:

- Standard connection ( L , N, PE ) .
- 3-phase connection where conductors L2 and L3 are continuous ( L1, L2, L3 , N, PE).
- DALI control connection ( L, N, PE, DA/L, DA/N)

When connecting, it is important to ensure that the wires are connected correctly and to secure them against loosening.

### 3. Tightening Torque:

The tightening torque for the flange nuts is **3.0 Nm** . Make sure the nuts are tightened sufficiently to ensure a firm and secure connection.

## 5. Safety notice

- Before installing the luminaire, carefully read all the information provided in the instructions.
- It is necessary to follow general safety rules.
- No other spare parts than those listed in the instructions may be used in the luminaires!
- If the seals or glands are damaged, they must be replaced!
- If a luminaire that has been in operation is reopened, the seal on the luminaire's protective glass must be replaced!
- The manufacturer bears no responsibility for the consequences caused by any arbitrary intervention in the luminaire.
- The manufacturer assumes no liability for damage resulting from incorrect installation, maintenance or improper use.
- In the event of a malfunction, the device must be switched off immediately.



## 6. Lamp maintenance

In order for an ATEX-certified luminaire to function and be safe over time, it is essential to maintain it regularly. Maintenance must be carried out in accordance with the manufacturer's instructions and the applicable explosion protection standards. The following instructions apply to aluminium luminaires intended for use in environments with an increased risk of explosion.

### 1. Regularly check the condition of the luminaire

- **Checking the seals** : Make sure that the silicone seals that provide protection against dust and water are intact. If worn, the seals must be replaced. A damaged seal can compromise the explosion protection.
- **Glass inspection** : Regularly check that the glass part of the luminaire is undamaged (no cracks or chips). Damaged glass must be replaced immediately to avoid the risk of explosion or sparks.
- **Checking cable glands** : Cable glands made of stainless steel must be checked regularly for signs of wear or corrosion. The glands should be sealed and free of mechanical damage.

### 2. Electrical connection

- **Connection Check** : Verify that all terminals are securely tightened and that the wire connections comply with the requirements for safe connections in hazardous areas.
- **Checking the insulation materials** : Check that the wires are not damaged or worn. Damaged insulation can pose a risk to the correct functioning of the luminaire and the safety of the environment.

### 3. Cleanliness and maintenance

- When cleaning an explosion-proof luminaire, it is important to take care to prevent electrostatic charging, which can be dangerous in environments with explosive substances.
  - **Preparation:**
    - Use an antistatic wrist strap or mat.
    - Clean in a dry environment, ideally away from explosive areas.
  - **Selection of cleaning materials:**
    - Use antistatic cloths and cleaning agents suitable for electrostatic protection.
    - Avoid metal tools and rough materials.
  - **Cleaning procedure:**
    - Turn off the light and disconnect it from the power supply.
    - Gently clean the exterior surfaces of the fixture to avoid causing charging.
  - **Completion:**
    - Make sure the light fixture is dry and clean before reconnecting.

### 4. Professional maintenance

- All maintenance activities must be carried out by qualified personnel who are familiar with safety regulations and requirements for explosive environments. In the event of any damage or suspected malfunction, the luminaire must be immediately taken out of service.



## 5. Check before each use

- Before each use of the luminaire, a visual inspection of all safety features, connections and seals must be carried out. Furthermore, check that the luminaire complies with the conditions of use specified in the technical description.

## 7. Spare parts

from the manufacturer available .

### 1. List of recommended spare parts

- **Light sources** : Replacement LED modules that meet the luminaire specifications .
- **Gasket** : Gasket No. 421. 2563A for glass covers and other parts of the luminaire is crucial for maintaining the required protection against dust, water and other contaminants.
- **Cable glands** : Cable glands M20x1.5 No. 13166 (metal), No. 13144 (Plastic) and M25x1.5 No. 13170 (Plastic), No. 13173 which are ATEX certified are essential to ensure safety in explosive environments. These glands must be compatible with the requirements for explosive areas and provide protection against ignition.
- **Holder** : Lamp holder No. 338.2783 must be stable to ensure proper installation and long life of the lamp.

### 2. Selection of compatible parts

- **Exact specifications** : Spare parts must be used from the luminaire manufacturer. The use of incompatible parts may compromise the safety of the luminaire and void the warranty!
- **Hazardous Area Approvals** : Make sure that spare parts are certified for use in explosive or hazardous environments. However, no parts other than those approved by the manufacturer may be used!

### 3. Maintenance and parts replacement

- **Regular inspection** : For a long service life, it is important to regularly check the condition of the luminaire , such as seals, cables, tempered glass , brackets and cable glands . If you find any wear or damage, contact the manufacturer immediately .
- **Replacement of parts** : When replacing any part, proper procedure and all safety standards must be observed. Replacement should only be performed by a qualified person who has the appropriate training and approval from the luminaire manufacturer.

### 4. Availability and ordering of spare parts

- **Clear catalog** : It is recommended to have a catalog with spare parts available . and contact the manufacturer.
- **Availability throughout the life of the luminaire** : Our company ensures the availability of spare parts throughout the life of the luminaire.



## 8. Packaging, delivery, storage and accompanying documentation

To ensure safe and trouble-free delivery and use of the product, it is necessary to follow several basic principles regarding packaging, storage and accompanying documentation .

- **Product packaging** : The product must be adequately protected during transport from external influences such as impacts, blows or moisture penetration. For this, it is necessary to use suitable packaging that ensures mechanical protection and protection against moisture, thus minimizing the risk of damage during transport.
- **Product Delivery** : When delivering a product, it is important to ensure that it is in a fully functional and undamaged condition, ready for assembly and commissioning. Delivery must be in accordance with the agreed terms and on time.
- **Product Storage** : To maintain optimal product functionality, it is essential that the product is stored indoors with a maximum relative humidity of 75% and a temperature between 5°C and 30°C. The product should be protected from extreme temperature and humidity changes that could negatively affect its performance.
- **Accompanying documentation** : All necessary documentation must be available upon delivery of the product, which includes:
  - **Technical description** product, which describes its parameters and functions in detail.
  - **Assembly instructions** , which provide detailed instructions for safe and correct installation.
  - **Dimensional drawing** , which shows the key dimensions and location of individual product components for easier assembly.
  - **Certificate of quality and completeness** , which confirms that the product meets all required standards and is complete.
  - **Warranty certificate** , which sets out the conditions and warranty period for the product, including information on the possibilities of making a claim.

This set of rules and documents will ensure that the product is properly protected, stored and delivered in the appropriate condition, which is essential for its long-term and trouble-free functionality.

## 9. Special conditions of use

- **The verified values** for the maximum width and minimum length of construction joints of this enclosure are different from the corresponding minimum or maximum values specified in the technical standard. The manufacturer must be contacted for information on joint dimensions.
- **Ambient temperature:**
  - $-40^{\circ}\text{C} \leq T_a \leq +50^{\circ}\text{C}$
- **For explosive dust atmospheres**, the enclosure must be installed in such a way as to prevent the risk of creeping discharges.



**Elektrosvit**

Svatoborice, a. s.

## 10. Dimensional sketch

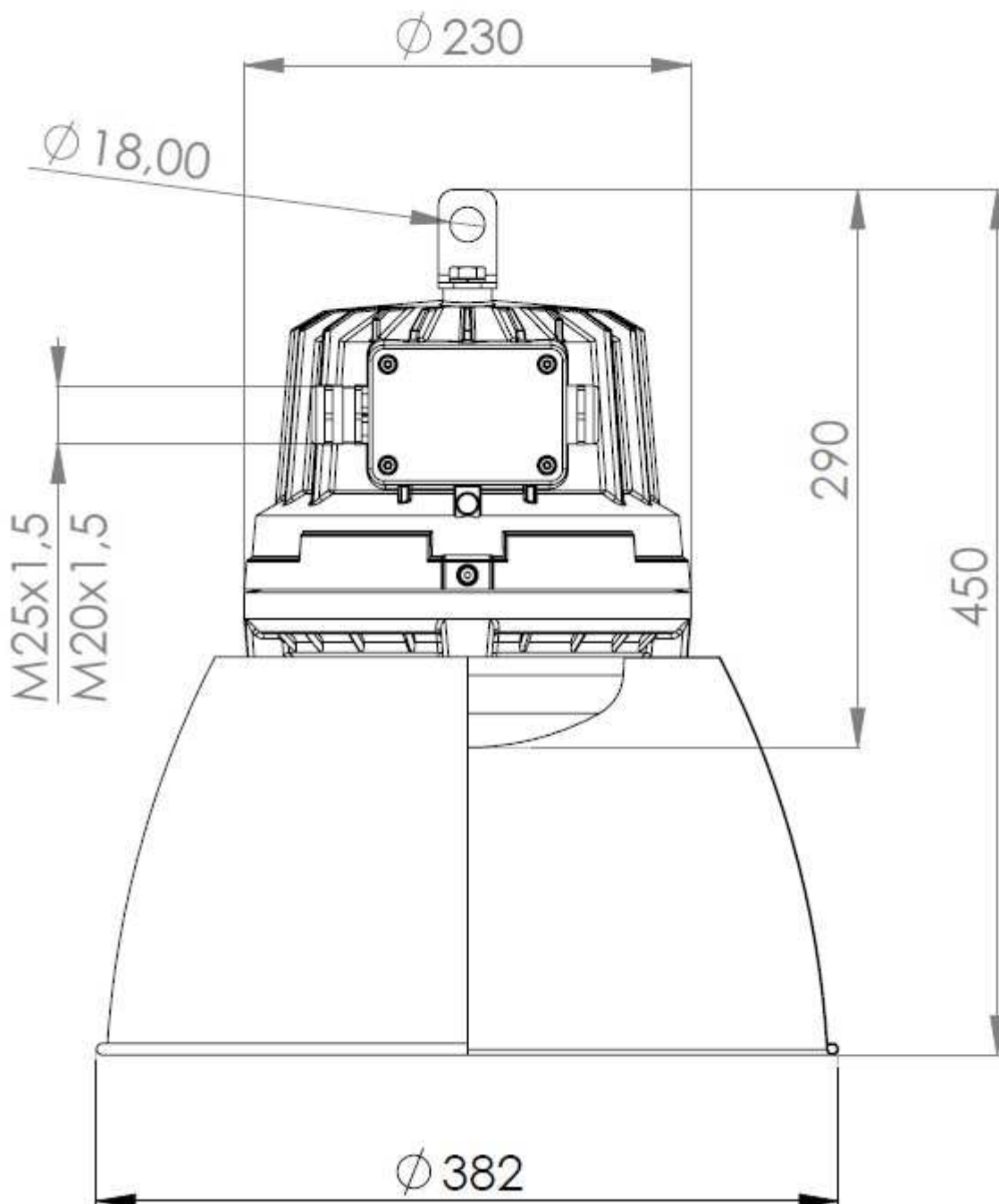



## 11. Configurator

**591 39 04 - 30 - 11 - M20 - 4K - DA - PB**

### 1 Typové označení svítidla

591 39 04 – 50W  
591 39 05 – 30W

30  
40  
50

10  
11

M20  
M25  
P20  
P25

3K  
4K  
5K  
5K7  
6K  
6K5

### 2 Typ připojení kabelů

30 - 3-polová svorkovnice  
40 - 4-polová svorkovnice  
50 - 5-polová svorkovnice

→	3	0
→	4	0
→	5	0

### 3 Počet vývodek

10 - jedna vývodka na jedné straně svítidla  
11 - jedna vývodka na obou stranách svítidla

1 0

1 1

### 4 Typ vývodek

M20 – Kov, 6 mm – 13 mm  
M25 – Kov, 9 mm – 17 mm  
P20 – Plast, 6 mm – 13 mm  
P25 – Plast, 9 mm – 17 mm

### 5 Teplota chromatičnosti

4K - 4000 K  
5K - 5000 K  
5K7 - 5700 K  
6K - 6000 K  
6K5 - 6500 K

### 6 Doplnkové možnosti

DA – připojení DALI řízení  
3F – 3-fázové zapojení

### 7 Doplnková výbava

PB – Ochranný ocelový koš  
LS – Stínidlo