

FARMER I LED

Light fitting for the illumination of indoor and outdoor industrial spaces.



591 36 01K

591 36 02K

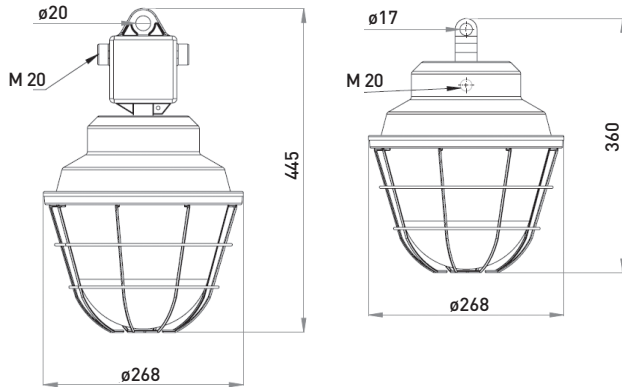

TECHNICAL DESCRIPTION

The body is made of steel sheet and finished with powder paint. The inorganic glass cover with seal and protective basket are fixed to the body with four metal caps. There is a LED module built inside the light fitting and it is comprised of a board fitted with LEDs and a power supply. According to the individual types, the light fitting includes: an ALSi terminal box, a steel pipe, or a galvanized steel sheet boom. The light fitting is made as a through light fitting and is provided with two cable outlets. The max. cross-section of the connecting conductors is 4 mm². The light fitting is produced with plastic cable gland as standard, metal gland is available on request.

INSTALLATION On the ceiling, wall.

VERSIONS Optional version of light fittings with reinforced corrosion protection – version „pz”, version with a protective steel basket – version „K”, version with a protective polycarbonate basket and stainless-steel caps – version „p”. Light fittings are provided with a self-resetting thermal fuse and surge guard up to 3 kV.

LIFETIME 50.000 hours, L80B20

CE		IP54 of 591 36 01 IP66 of 591 36 02
	198 - 264V AC 176 - 276V DC	Ta -30°C ÷ +40°C
Carton (mm/pcs) 1000 x 280 x 280 / 1 650 x 280 x 280 / 2 650 x 320 x 280 / 2		

Type	Power input [W] / Luminous flux [lm]	Luminous efficiency [lm/W]	Angle of beam [°]	Colour temperature [K]	CRI	Part of light fitting	Weight [kg]
591 36 01 (K)	30 / 4300	144	120	4000, 5000, 5700, 6500	>80	Terminal box	4,8
591 36 02 (K)	30 / 4300	144	120	4000, 5000, 5700, 6500	>80	Holder	4,8

*By adding the letter „K” after the type designation, the light fittings will be provided with protective baskets (591 36 01 K).

**By adding the letter „p” after the type designation, the light fittings will be made with protective polycarbonate baskets and stainless-steel caps – for harsh conditions (591 36 01 p).

***By adding the letters „pz” after the type designation, the light fittings will be made with reinforced corrosion protection – for extra harsh conditions (591 36 01 Kpz).

MAXIMUM CIRCUIT BREAKER LOAD AND NUMBER OF LUMINAIRES CONNECTED IN SERIES

Circuit breaker	B16
Amount of luminaires max	50
Conductor cross-section	2,5

Starting current I _{max}	time
5A	50us

* Actual values may vary due to the types of circuit breakers used and the installation environment.



593 36 04K

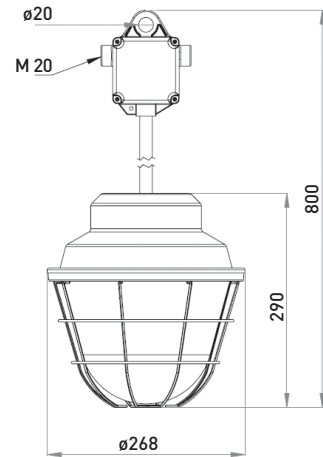

592 36 03K

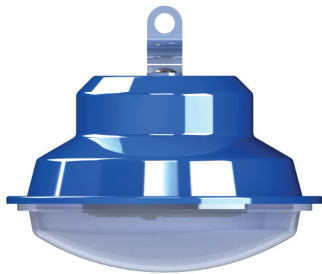
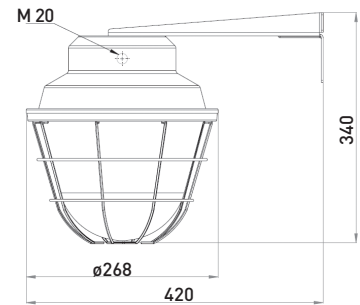

COMING SOON

Low glass for all versions of the FARMER luminaire.

CE		50 Hz 60 Hz	198 - 264V AC 176 - 276V DC
IP54 of 592 36 03 IP66 of 593 36 04		LED	Ta -30°C ÷ +40°C
Carton (mm/pcs)		1000 x 280 x 280 / 1 650 x 280 x 280 / 2 650 x 320 x 280 / 2	

Type	Power input [W] / Luminous flux [lm]	Luminous efficiency [lm/W]	Angle of beam [°]	Colour temperature [K]	CRI	Part of light fitting	Weight [kg]
592 36 03 (K)	30 / 4300	144	120	4000, 5000, 5700, 6500	>80	Pipe and terminal box	4,8
593 36 04 (K)	30 / 4300	144	120	4000, 5000, 5700, 6500	>80	Boom	4,8

*By adding the letter „K” after the type designation, the light fittings will be provided with protective baskets (591 36 01 K).

**By adding the letter „p” after the type designation, the light fittings will be made with protective polycarbonate baskets and stainless-steel caps – for harsh conditions (591 36 01 p).

***By adding the letters „pz” after the type designation, the light fittings will be made with reinforced corrosion protection – for extra harsh conditions (591 36 01 Kpz).

TO ORDER



Glass cover
232.5068/1



Protective steel
basket
1-99.6231

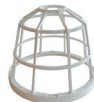

Protective basket
polycarbonate 182.2540
PMMA 182.5005



Stainless steel cap
4-99.6180/01



Metal cap
4-99.8470/01